



F54/320 - IMC Vulture 1604 Floor-mounted Food Waste Disposer - 3 Phase [4 wire] - W 514 mm - 4.0 kW

Reliable, efficient, safe and easy to operate, the 1604 Waste Disposer allows operators to quickly and effectively remove waste, to create a safer and cleaner kitchen.

- ✓ Fast and efficient disposal of up to 900kg of food waste per hour.
- ✓ Manually reversible motor to extend operational life.
- ✓ Handles up to 1850 covers per sitting - ideal for large kitchens.
- ✓ Suitable for large kitchens with three-phase, four-wire power supply.
- ✓ For tough waste (red meat bones, cauliflower stalks and fish skins).

Specifications

Summary

Brand	IMC
Range	Vulture
Series	04 Series
Power Type	Electric
Unit Type	Floor-mounted or welded into tabling [with optiona
Available in UK Only	No
UK Warranty	2 Years Parts and Labour Warranty
Export Warranty	Contact your local dealer
Mounting	Floor-mounted
GTIN	5056105199144

Power and Performance

Total Power kW	4
HP	5.4
IP Rating	IP55

Key Specifications

Operator Safety	Interlocks
Airbreak	No

Capacity

Type of Waste	Tough waste
Covers Per Sitting	1850
Capacity Kg per Hour	900

Weights and Dimensions

Unit Height (External) mm	850
Unit Width (External) mm	514
Unit Depth (External) mm	740
Net Weight Kg	85.5

Supply Connections

Requires Installation	Yes
Requires Electrical Supply	Yes
UK 3 Pin Plug	No
Requires Hardwiring	Yes
Electrical Supply Rating Watts	4000
Three Phase Amps	9.4
Three Phase Voltage	400
Water Supplied From	Storage cistern
Water Connection Pressure Bar	0.18
Drain Connection	2" BSP threaded flange, connected to 54mm piping;
Water Connection	22mm

Shipping

Packed Weight Kg	94.05
Packed Height cm	105
Packed Width cm	90
Packed Depth cm	54

Available Options

MAG CUTLERY SAVER

VS279 1204/1204X/1604/1604X MAGNETIC CUTLERY SAVER

WATER FLOW CONTROL

VS356 1204/1604 WATER FLOW CONTROL

REMOTE CONTROL

S54/026 1204X/1604X REMOTE CONTROL BOX

Technical Picture

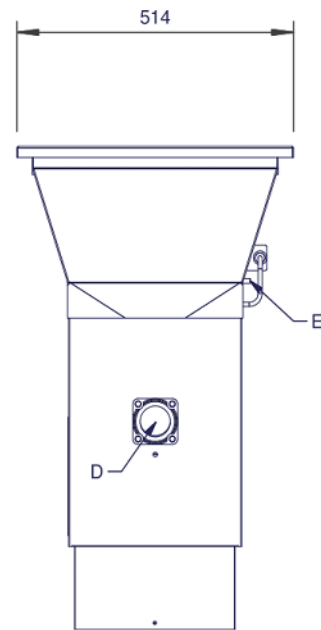
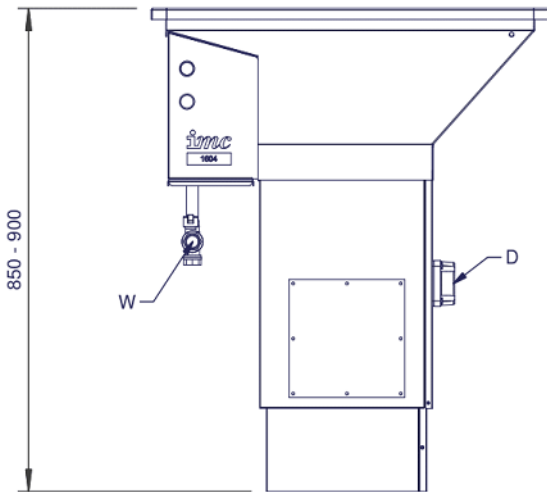
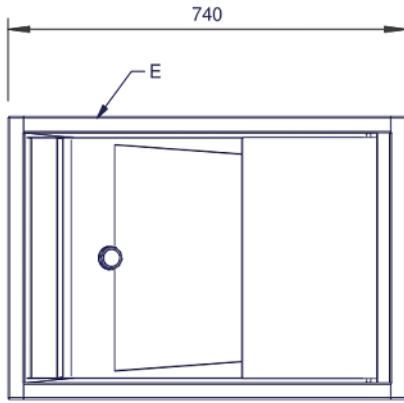

Lincat Limited

Whisby Road,
Lincoln, LN6 3QZ,
United Kingdom

Company No: 2175448

A member company of



Customer Care

Tel: +44 1522 875500
Email: care@lincat.co.uk

Export Customers

Tel: +44 1522 875536
Email: export@lincat.co.uk

Opening Hours

Monday – Friday:
8.30am – 5pm