



F54/725 - IMC Vulture 1204X Floor-mounted Food Waste Disposer - 3 Phase [4 wire][air break] - W 514 mm - 2.2 kW

Reliable, efficient, safe and easy to operate, the 1204X Waste Disposer allows operators to quickly and effectively remove waste, to create a safer and cleaner kitchen.

- ✓ Fast and efficient disposal of up to 700kg of food waste per hour.
- ✓ Handles up to 1450 covers per sitting - ideal for large kitchens.
- ✓ For tough waste (red meat bones, cauliflower stalks and fish skins).
- ✓ Free-standing design, but can be welded into tabling with E30/096 hopper rim.
- ✓ Manually reversible motor to extend operational life.
- ✓ Low-load cut-outs ensure energy and water efficiency.
- ✓ Fitted with a with class A airbreak kit, recommended for when connecting to a mains water supply.
- ✓ Suitable for large kitchens with three-phase, four-wire power supply.

Specifications

Summary

Brand	IMC
Range	Vulture
Series	04X Series
Power Type	Electric
Unit Type	Floor-mounted or welded into tabling [with optiona
Available in UK Only	No
UK Warranty	2 Years Parts and Labour Warranty
Export Warranty	Contact your local dealer
Mounting	Floor-mounted
GTIN	5056105199113

Power and Performance

Total Power kW	2.2
HP	3
IP Rating	IP55

Key Specifications

Operator Safety	Interlocks
Airbreak	Yes

Capacity

Type of Waste	Tough waste
Covers Per Sitting	1450
Capacity Kg per Hour	700

Weights and Dimensions

Unit Height (External) mm	1014
Unit Width (External) mm	514
Unit Depth (External) mm	740
Net Weight Kg	74

Supply Connections

Requires Installation	Yes
Requires Electrical Supply	Yes
UK 3 Pin Plug	No
Requires Hardwiring	Yes
Electrical Supply Rating Watts	2200
Three Phase Amps	5.1
Three Phase Voltage	400
Water Supplied From	Mains or storage cistern
Water Connection Pressure Bar	0.18
Drain Connection	2" BSP threaded flange, connected to 54mm piping;
Water Connection	22mm

Shipping

Packed Weight Kg	81.4
Packed Height cm	105
Packed Width cm	79
Packed Depth cm	54

Available Options

MAG CUTLERY SAVER

VS279 1204/1204X/1604/1604X MAGNETIC CUTLERY SAVER

REMOTE CONTROL BOX

S54/026 1204X REMOTE CONTROL BOX

Available Accessories

E30/096 Hopper Rim for 1204/1204X/1604/1604X Food Waste Disposer

Technical Picture

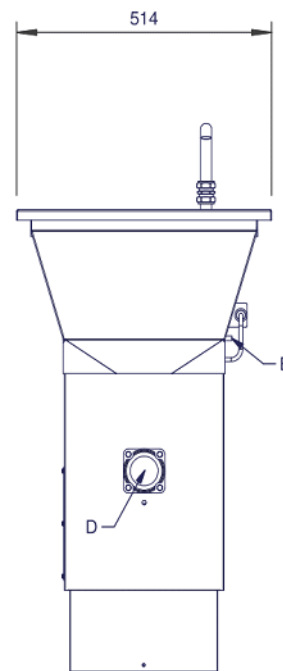
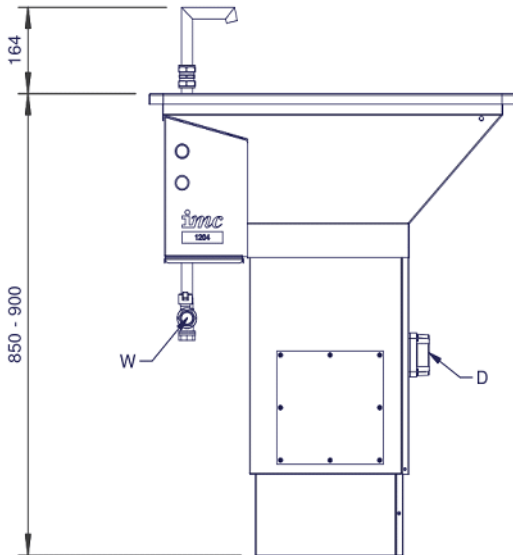
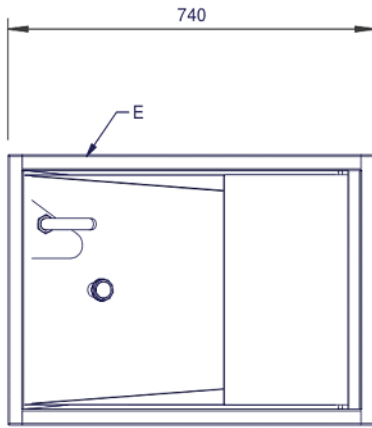

Lincat Limited

Whisby Road,
Lincoln, LN6 3QZ,
United Kingdom

Company No: 2175448

A member company of



Customer Care

Tel: +44 1522 875500
Email: care@lincat.co.uk

Export Customers

Tel: +44 1522 875536
Email: export@lincat.co.uk

Opening Hours

Monday – Friday:
8.30am – 5pm