



F59/510/L - IMC MF10L Free-standing Vegetable Peeler - with Carborundum Liner - 1 Phase - W 481 mm - 0.37 kW

The high-output, versatile MF10L (1PH) can be used to quickly peel a range of vegetables - making it an ideal addition for medium to large kitchens.

- ✓ Able to peel up to 322kg of vegetables per hour - in 10kg batches.
- ✓ With carborundum liner to reduce peeling times even further.
- ✓ Interlocking lid and door ensure safe operation.
- ✓ Perspex viewing pane allows you to monitor the peeling progress.
- ✓ Adjustable timer ensures accurate, repeatable peeling times.
- ✓ Modular construction facilitates easy maintenance.
- ✓ Thicker peeling plate delivers longer operating life.
- ✓ Suitable for small to medium kitchens with single-phase power supply.

Specifications

Summary

| | |
|-----------------------------|-----------------------------------|
| Brand | IMC |
| Range | MF Multi-Functional Peeler |
| Power Type | Electric |
| Unit Type | Free-standing |
| Available in UK Only | No |
| UK Warranty | 2 Years Parts and Labour Warranty |
| Export Warranty | Contact your local dealer |
| Mounting | Free-standing |
| GTIN | 5056105198642 |

Power and Performance

| | |
|-----------------------|------|
| Total Power kW | 0.37 |
| HP | 0.5 |
| IP Rating | IP55 |

Key Specifications

| | |
|------------------------|----------------|
| Operator Safety | Interlocks |
| Timer | Yes |
| Drain Location | Rear and under |
| Airbreak | Yes |

Capacity

| | |
|-----------------------------|-----|
| Capacity Kg per Hour | 322 |
|-----------------------------|-----|

Weights and Dimensions

| | |
|----------------------------------|------|
| Unit Height (External) mm | 1105 |
| Unit Width (External) mm | 481 |
| Unit Depth (External) mm | 633 |
| Net Weight Kg | 52 |

Supply Connections

| | |
|--------------------------------------|---------------------|
| Requires Installation | Yes |
| Requires Electrical Supply | Yes |
| UK 3 Pin Plug | No |
| Requires Hardwiring | Yes |
| Motor Rating Watts | 370 |
| Single Phase Amps | 3.6 |
| Single Phase Voltage | 230 |
| Water Connection Pressure Bar | 2.7-3.8 [40-55 psi] |
| Drain Connection | 38mm |
| Water Connection | 12mm |

Shipping

| | |
|-------------------------|------|
| Packed Weight Kg | 57.2 |
| Packed Height cm | 117 |
| Packed Width cm | 68 |
| Packed Depth cm | 51 |

Available Accessories

| | |
|----------------|--|
| E72/011 | Sink Skip - Stainless Steel - for MF10/MF10L/MF15/MF15L/VQ Peeler |
| S58/062 | Inlet Hose Kit for MF10/MF10L/MF15/MF15L Vegetable Peeler |
| S59/164 | Carborundum Peeling Plate for MF10/MF10L/MF15/MF15L Vegetable Peeler |

Technical Picture

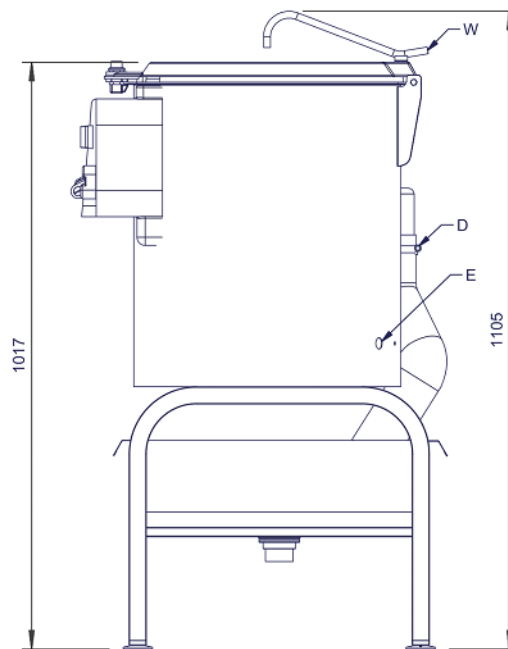
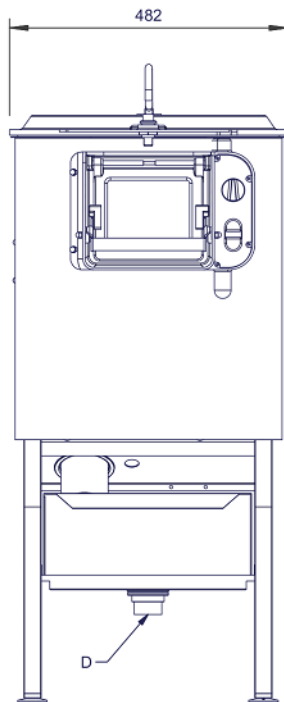
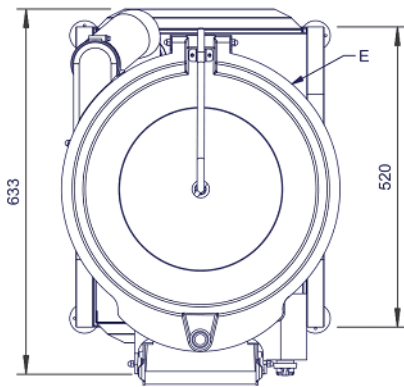



Lincat Limited

Whisby Road,
Lincoln, LN6 3QZ,
United Kingdom

Company No: 2175448

A member company of



Customer Care

Tel: +44 1522 875500
Email: care@lincat.co.uk

Export Customers

Tel: +44 1522 875536
Email: export@lincat.co.uk

Opening Hours

Monday – Friday:
8.30am – 5pm