



F60/100 - IMC Vulture 725 In-tabling Food Waste Disposer - 1 Phase - W 338 mm - 1.1 kW

Reliable, efficient, safe and easy to operate, the compact 725 Waste Disposer allows operators to quickly and effectively remove waste, to create a safer and cleaner kitchen.

- ✓ Fast and efficient disposal of up to 400kg of food waste per hour.
- ✓ Compact design allows hopper to be table-mounted, for quick and easy loading.
- ✓ Handles up to 850 covers per sitting - ideal for medium-size kitchens.
- ✓ Manually reversible motor to extend operational life.
- ✓ For medium waste (plate waste, vegetables and peelings, meat and fish scraps).
- ✓ Suitable for medium kitchens with single-phase power supply.

Specifications

Summary

Brand	IMC
Range	Vulture
Series	700 Series
Power Type	Electric
Unit Type	Welded into tabling
Available in UK Only	No
UK Warranty	2 Years Parts and Labour Warranty
Export Warranty	Contact your local dealer
Mounting	In-tabling
GTIN	5056105199526

Power and Performance

Total Power kW	1.1
HP	1.5
IP Rating	IP55

Key Specifications

Operator Safety	Interlocks
Airbreak	No

Capacity

Type of Waste	Medium waste
Covers Per Sitting	850
Capacity Kg per Hour	400

Weights and Dimensions

Unit Height (External) mm	733
Unit Width (External) mm	340
Unit Depth (External) mm	472
Net Weight Kg	39.5

Supply Connections

Requires Installation	Yes
Requires Electrical Supply	Yes
UK 3 Pin Plug	No
Requires Hardwiring	Yes
Electrical Supply Rating Watts	1100
Single Phase Amps	7.4
Single Phase Voltage	230
Water Supplied From	Storage cistern
Water Connection Pressure Bar	0.4
Drain Connection	2" BSP threaded flange, connected to 54mm piping;
Water Connection	15mm

Shipping

Packed Weight Kg	43.45
Packed Height cm	104
Packed Width cm	63
Packed Depth cm	48

Available Options

MAG CUTLERY SAVER

VS167

700/800/904/904X MAGNETIC CUTLERY SAVER

WATER FLOW CONTROL

VS355

725 WATER FLOW CONTROL

Technical Picture

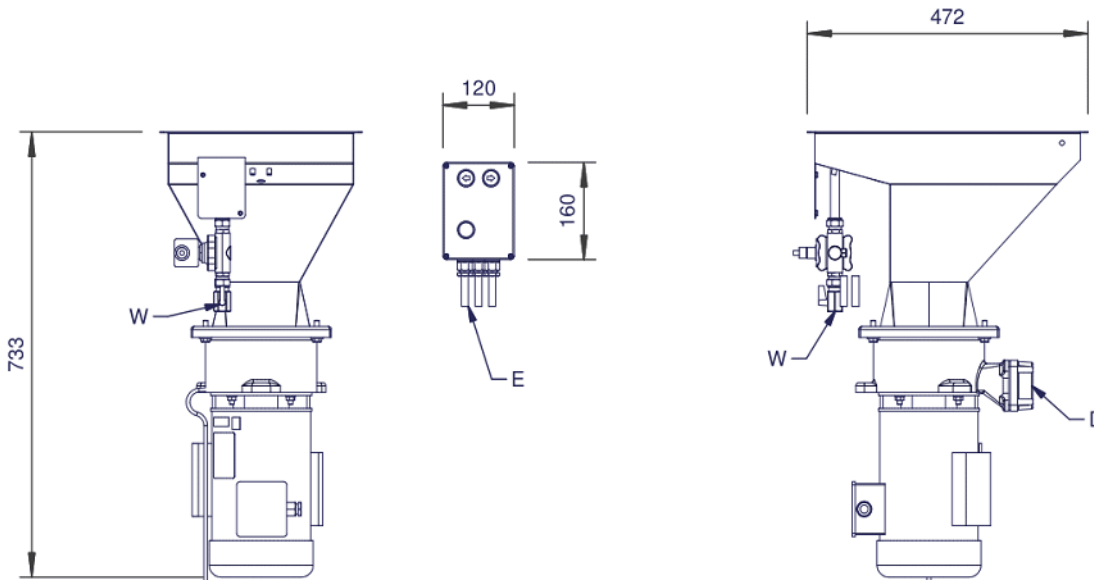
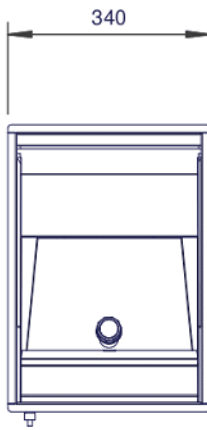



Lincat Limited

Whisby Road,
Lincoln, LN6 3QZ,
United Kingdom

Company No: 2175448

A member company of



Customer Care

Tel: +44 1522 875500
Email: care@lincat.co.uk

Export Customers

Tel: +44 1522 875536
Email: export@lincat.co.uk

Opening Hours

Monday – Friday:
8.30am – 5pm