



F63/500 - IMC Mobile Hand Wash Station - W 450mm - 3.0kW

With enough for 85 hand washes per fill, the sturdy Mobile Hand Wash Station is perfect for increasing hygiene standards where there is no access to mains water, and can be used wherever it's required.

- ✔ Provides hand washing facility in locations where mains water isn't available.
- ✔ Ideal for increasing hygienic hand washing facilities wherever required - just fill, plug in and go.
- ✔ Provides 85 hand washes - 10 litres per fill.
- ✔ Internal waste collection - no need for drainage.
- ✔ Water temperature limited to 42°C for user safety.
- ✔ Foot-activated, infrared-operated tap make unit hygienic, with no need for hand contact.
- ✔ Large wheels make hand wash station quick and easy to move.
- ✔ Constructed from sturdy and hygienic stainless steel, making it easy to wipe clean

Specifications

Summary

Brand	IMC
Range	IMClean
Series	Mobile Hand Wash
Power Type	Electric
Available in UK Only	No
UK Warranty	1 Year Parts and Labour Warranty
Export Warranty	Contact your local dealer
GTIN	5056105198017

Power and Performance

Total Power kW	3
Water Temperature °C	42 constant
IP Rating	IPX4
Temperature Control	Set at factory
Drain Method	Flexible pipe to removable waste container

Key Specifications

Waste Collection	Internal removable container [supplied]
Drain Location	Bottom of water tank
Outlet	Foot-activated infrared-operated tap
Number of Sinks	1

Capacity

Capacity Litres	10
------------------------	----

Weights and Dimensions

Unit Height (External) mm	1136
Unit Width (External) mm	450
Unit Depth (External) mm	543
Height to Sink mm	950
Net Weight Kg	29

Supply Connections

Requires Installation	No
Requires Electrical Supply	Yes
UK 3 Pin Plug	Yes
Requires Hardwiring	No
Electrical Supply Rating Watts	3000
Single Phase Amps	12
Single Phase Voltage	230

Shipping

Packed Weight Kg	31.9
Packed Height cm	125
Packed Width cm	68
Packed Depth cm	57

Available Accessories

S63/123

Splashback, Soap and Paper Towel Holder for Mobile Handwash Station

Available Accessories

- S63/222** Bin Bag Holder for Mobile Hand Wash Station [inc. 20 x Bin Bags]
- S63/223** Bin Bags for Mobile Hand Wash Station [Pk 20][fits S63/222 Holder]

Technical Picture

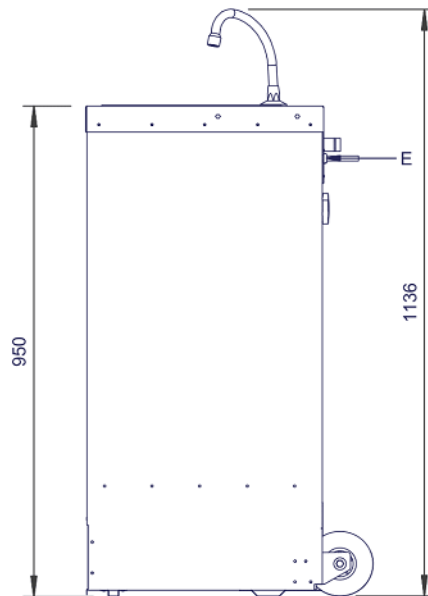
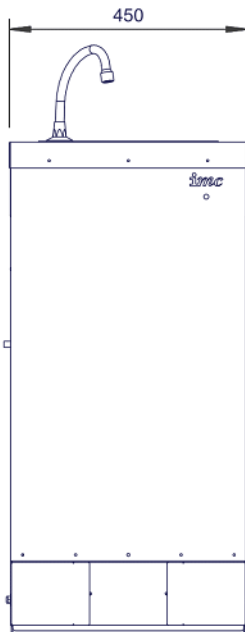
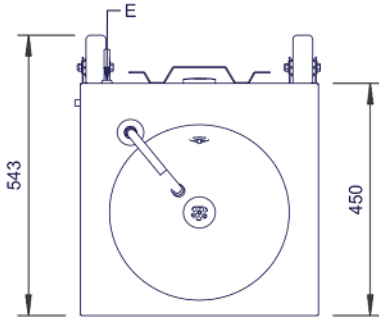



Lincat Limited

Whisby Road,
Lincoln, LN6 3QZ,
United Kingdom

Company No: 2175448

A member company of



Customer Care

Tel: +44 1522 875500
Email: care@lincat.co.uk

Export Customers

Tel: +44 1522 875536
Email: export@lincat.co.uk

Opening Hours

Monday – Friday:
8.30am – 5pm