



F68/120 - IMC Vulture 825 In-tabling Food Waste Disposer - 3 Phase [5 wire] - W 360 mm - 2.2 kW

Reliable, efficient, safe and easy to operate, the compact 825 Waste Disposer allows operators to quickly and effectively remove waste, to create a safer and cleaner kitchen.

- ✓ Fast and efficient disposal of up to 600kg of food waste per hour.
- ✓ Compact design, welded into tabling, for quick and easy loading.
- ✓ Handles up to 1350 covers per sitting - ideal for large kitchens.
- ✓ Manually reversible motor to extend operational life.
- ✓ For tough waste (red meat bones, cauliflower stalks and fish skins).
- ✓ Suitable for large kitchens with three-phase, five-wire power supply.

Specifications

Summary

Brand	IMC
Range	Vulture
Series	800 Series
Power Type	Electric
Unit Type	Welded into tabling
Available in UK Only	No
UK Warranty	2 Years Parts and Labour Warranty
Export Warranty	Contact your local dealer
Mounting	In-tabling
GTIN	5056105199649

Power and Performance

Total Power kW	2.2
HP	3
IP Rating	IP55

Key Specifications

Operator Safety	Interlocks
Airbreak	No

Capacity

Type of Waste	Tough waste
Covers Per Sitting	1350
Capacity Kg per Hour	600

Weights and Dimensions

Unit Height (External) mm	783
Unit Width (External) mm	360
Unit Depth (External) mm	530
Net Weight Kg	51

Supply Connections

Requires Installation	Yes
Requires Electrical Supply	Yes
UK 3 Pin Plug	No
Requires Hardwiring	Yes
Electrical Supply Rating Watts	2200
Three Phase Amps	5.3
Three Phase Voltage	400
Water Supplied From	Storage cistern
Water Connection Pressure Bar	0.4
Drain Connection	2" BSP threaded flange, connected to 54mm piping;
Water Connection	15mm

Shipping

Packed Weight Kg	56.1
Packed Height cm	104
Packed Width cm	63
Packed Depth cm	48

Available Options

MAG CUTLERY SAVER

VS167

700/800/904/904X MAGNETIC CUTLERY SAVER

WATER FLOW CONTROL

VS357

825 WATER FLOW CONTROL

Technical Picture

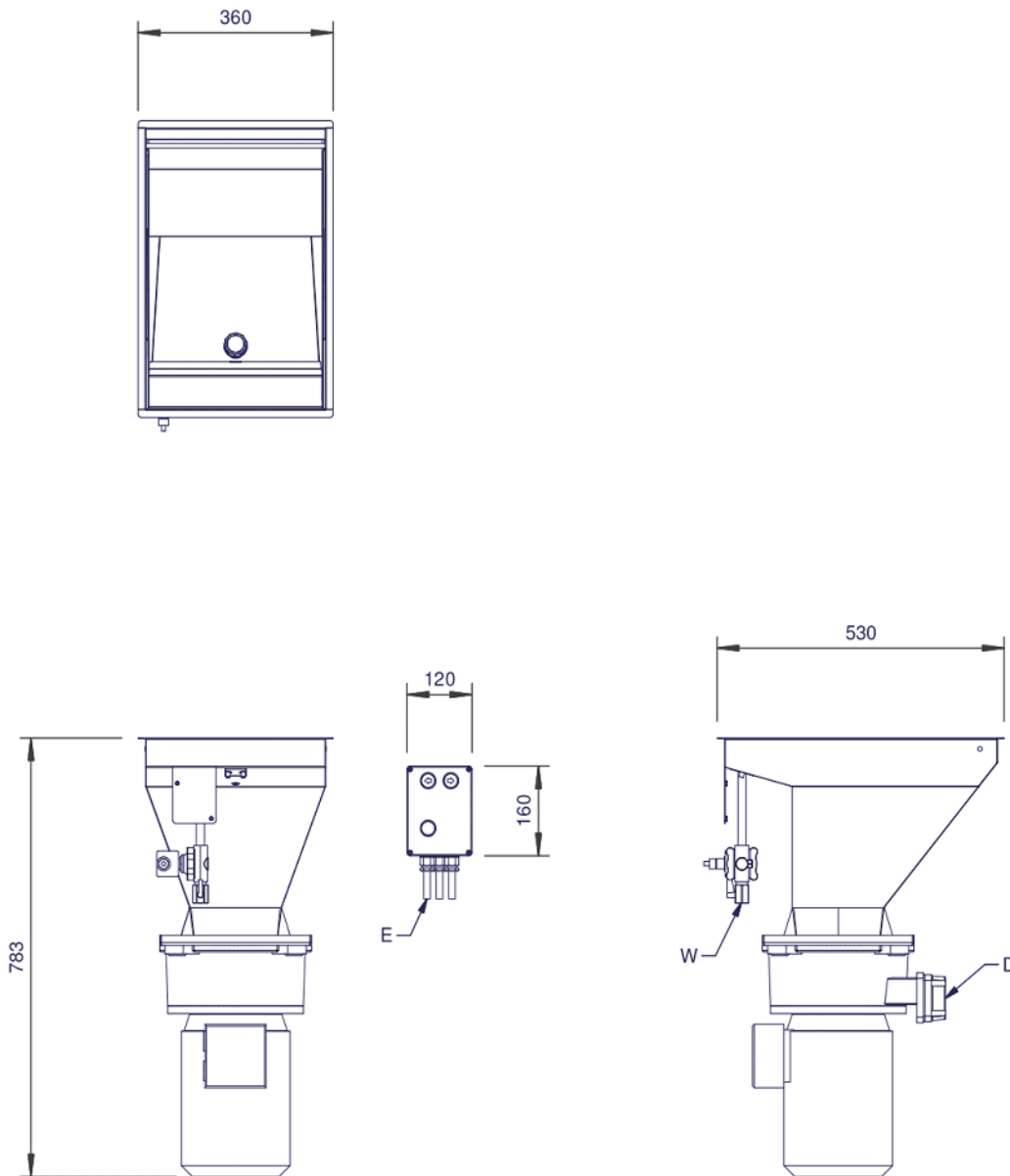



Lincat Limited

Whisby Road,
Lincoln, LN6 3QZ,
United Kingdom

Company No: 2175448

A member company of



Customer Care

Tel: +44 1522 875500
Email: care@lincat.co.uk

Export Customers

Tel: +44 1522 875536
Email: export@lincat.co.uk

Opening Hours

Monday – Friday:
8.30am – 5pm