



## F68/121 - IMC Vulture 825 In-tabling Food Waste Disposer - 3 Phase [4 wire] - W 360 mm - 2.2 kW

Reliable, efficient, safe and easy to operate, the compact 825 Waste Disposer allows operators to quickly and effectively remove waste, to create a safer and cleaner kitchen.

- ✔ Fast and efficient disposal of up to 600kg of food waste per hour.
- ✔ Compact design, welded into tabling, for quick and easy loading.
- ✔ Handles up to 1350 covers per sitting - ideal for large kitchens.
- ✔ Manually reversible motor to extend operational life.
- ✔ For tough waste (red meat bones, cauliflower stalks and fish skins).
- ✔ Suitable for medium kitchens with three-phase, four-wire power supply.

### Specifications

#### Summary

<b>Brand</b>	IMC
<b>Range</b>	Vulture
<b>Series</b>	800 Series
<b>Power Type</b>	Electric
<b>Unit Type</b>	Welded into tabling
<b>Available in UK Only</b>	No
<b>UK Warranty</b>	2 Years Parts and Labour Warranty
<b>Export Warranty</b>	Contact your local dealer
<b>Mounting</b>	In-tabling
<b>GTIN</b>	5056105199625

#### Power and Performance

<b>Total Power kW</b>	2.2
<b>HP</b>	3
<b>IP Rating</b>	IP55

#### Key Specifications

<b>Operator Safety</b>	Interlocks
<b>Airbreak</b>	No

#### Capacity

<b>Type of Waste</b>	Tough waste
<b>Covers Per Sitting</b>	1350
<b>Capacity Kg per Hour</b>	600

#### Weights and Dimensions

<b>Unit Height (External) mm</b>	783
<b>Unit Width (External) mm</b>	360
<b>Unit Depth (External) mm</b>	530
<b>Net Weight Kg</b>	51

#### Supply Connections

<b>Requires Installation</b>	Yes
<b>Requires Electrical Supply</b>	Yes
<b>UK 3 Pin Plug</b>	No
<b>Requires Hardwiring</b>	Yes
<b>Electrical Supply Rating Watts</b>	2200
<b>Three Phase Amps</b>	5.3
<b>Three Phase Voltage</b>	400
<b>Water Supplied From</b>	Storage cistern
<b>Water Connection Pressure Bar</b>	0.4
<b>Drain Connection</b>	2" BSP threaded flange, connected to 54mm piping;
<b>Water Connection</b>	15mm

#### Shipping

<b>Packed Weight Kg</b>	56.1
<b>Packed Height cm</b>	104
<b>Packed Width cm</b>	63
<b>Packed Depth cm</b>	48

**Available Options**

**MAG CUTLERY SAVER**

**VS167**

700/800/904/904X MAGNETIC CUTLERY SAVER

**WATER FLOW CONTROL**

**VS357**

825 WATER FLOW CONTROL

**Technical Picture**

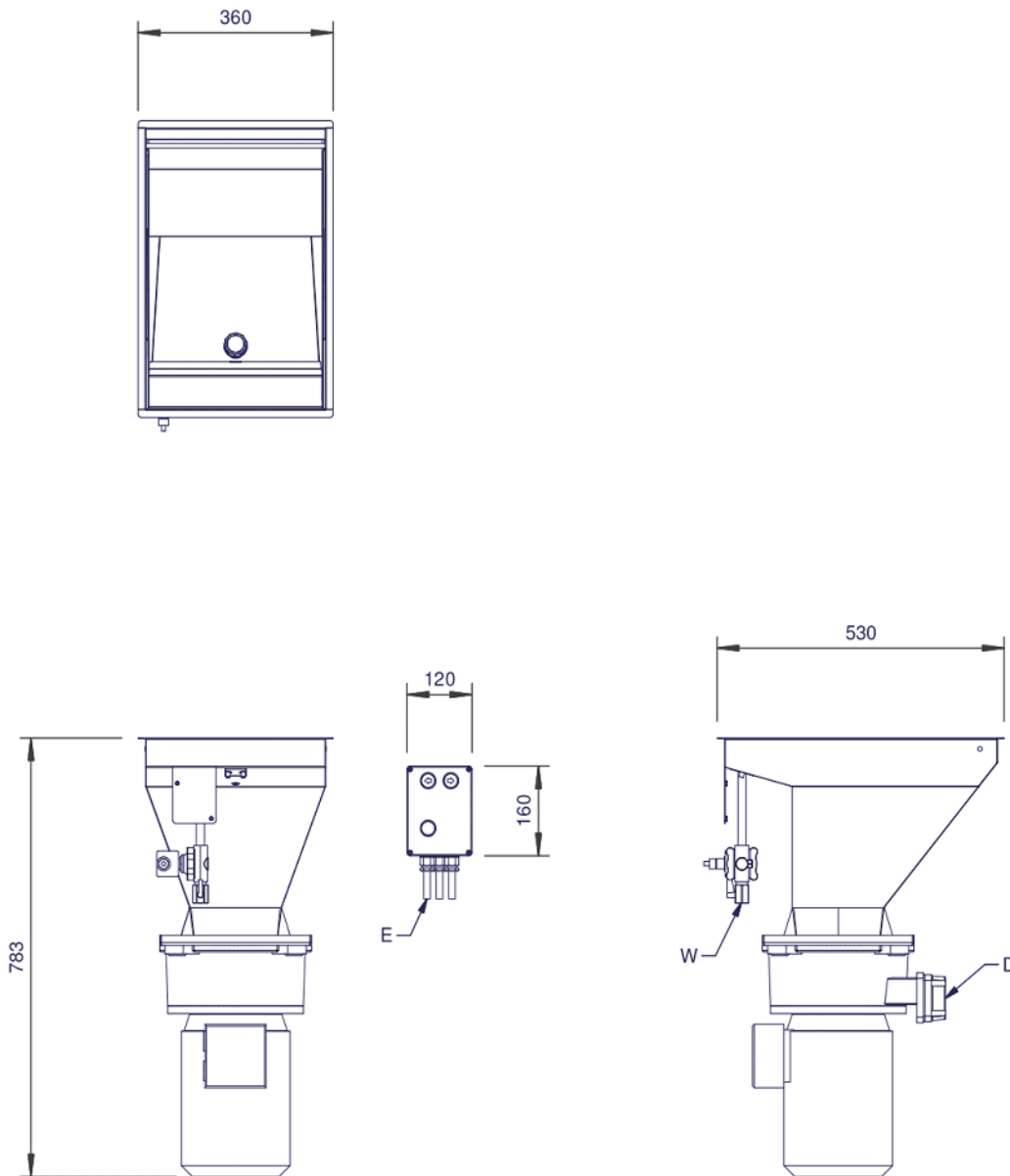



**Lincat Limited**

Whisby Road,  
Lincoln, LN6 3QZ,  
United Kingdom

**Company No:** 2175448

A member company of



**Customer Care**

**Tel:** +44 1522 875500  
**Email:** care@lincat.co.uk

**Export Customers**

**Tel:** +44 1522 875536  
**Email:** export@lincat.co.uk

**Opening Hours**

**Monday – Friday:**  
8.30am – 5pm