



L6018WB - Lincat Free-standing Wall Bench - W 1800 mm

Prepare delicious dishes with confidence on this strong, reliable Lincat Wall Bench.

- ✔ High quality 304 grade stainless steel resists corrosion & is easy to clean – maintaining a hygienic working space
- ✔ Quick and simple to assemble
- ✔ Features undershelves for maximum space
- ✔ Sound deadening design – reduces noise, by dulling the sounds of impact
- ✔ Adjustable feet that create a level working surface
- ✔ Supplied flat packed for safe and economic transportation

Specifications

Summary

Brand	Lincat
Range	Specialist
Unit Type	Free-standing
Available in UK Only	No
UK Warranty	2 Years Parts and Labour Warranty
Export Warranty	Contact your local dealer
GTIN	5056105101918

Key Specifications

Number of Shelves included	2
Number of Shelf Positions	2

Weights and Dimensions

Unit Height (External) mm	960
Unit Width (External) mm	1800
Unit Depth (External) mm	600
Shelf Dimensions Width mm	2 x 826 x 450
Shelf Dimensions Depth mm	450
Net Weight Kg	31.5

Shipping

Packed Weight Kg	34.65
Packed Height cm	32
Packed Width cm	180
Packed Depth cm	80

Technical Picture

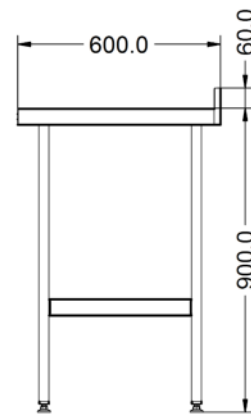
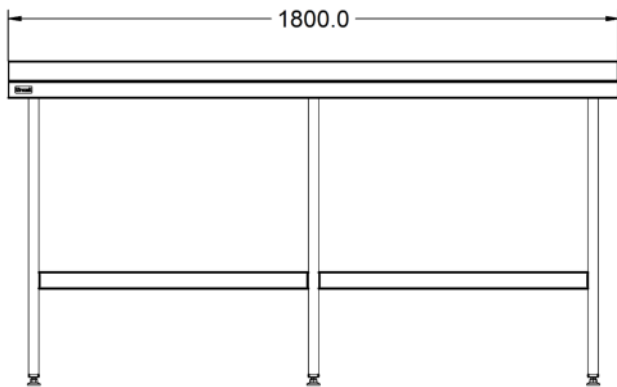
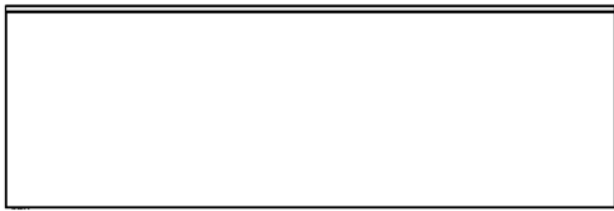

Lincat Limited

Whisby Road,
Lincoln, LN6 3QZ,
United Kingdom

Company No: 2175448

A member company of



Customer Care

Tel: +44 1522 875500
Email: care@lincat.co.uk

Export Customers

Tel: +44 1522 875536
Email: export@lincat.co.uk

Opening Hours

Monday – Friday:
8.30am – 5pm