



DOMINA PRO 900 - FRYERS

## FRBE94A



### 1 BOWL, ELECTRIC ON CLOSED STAND

#### TECHNICAL DATA:

External dimensions - WxDxH (cm)	40x90x85
Tank capacity (lt-GN)	18
Total power (kW)	16
IPX5	●

#### ADDITIONAL TECHNICAL DATA:

Tank dimensions - WxDxH (cm)	30x40x20
Electric elements (kW)	16
Supply (N)	400V 3N 50/60Hz
Weight (kg)	56
Volume (m3)	0,5

The 18/10 AISI 304 stainless steel tanks are continuous-welded with rounded corners for easy cleaning and sanification. All models have safety thermostat and thermostatic temperature control to keep the oil temperature within safety parameters. The used oil outlet system is simple and safe with an oil collection tank with stainless steel filter.

Gas versions: models available with direct heating via heating elements in the tank or with indirect heating via a burner outside the V-shaped tank, which guarantees excellent cleaning.

Electric versions: with liftable heating elements to guarantee perfect cleaning of the tank, versions with digital display are also available (FRBE94AD - FRBE98AD - FRBE94AHP) equipped with automatic melting, they allow precise control of the oil temperature, the setting of the cooking time and the setting of automatic programs to set and speed up the most frequent cooking. The HP model also ensures maximum responsiveness essential for obtaining high productivity in small spaces.

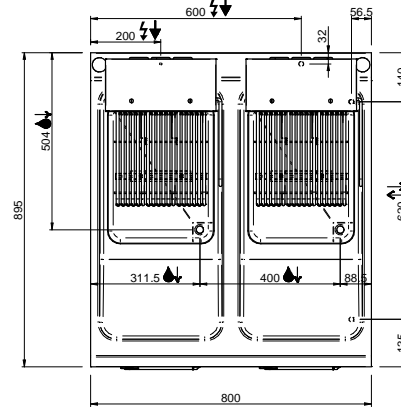
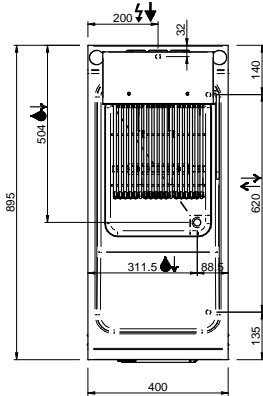
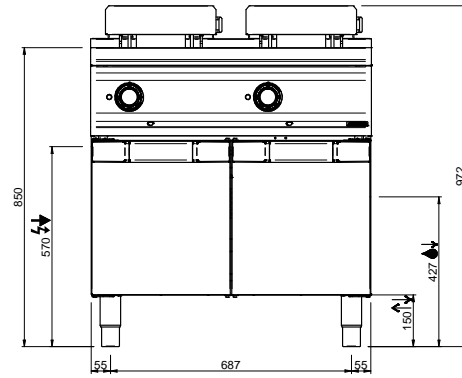
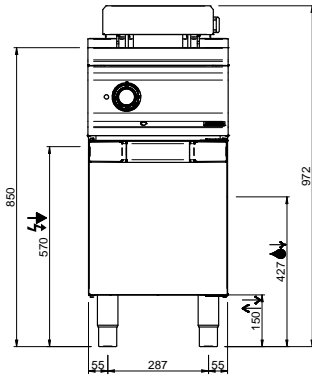

LEGENDA SIMBOLI / LEGEND



INGRESSO GAS / GAS INLET  
(EN 10226-1) Ø M 1/2"



INGRESSO ACQUA /  
WATER INLET Ø M 1/2"



ATTACCO EQUIPOTENZIALE /  
EQUIPOTENTIAL



ALIMENTAZIONE ELETTRICA /  
POWER SUPPLY



SCARICO ACQUA / OLII  
WATER / OILS DRAIN



REGOLAZIONE PIEDINI /  
FEET ADJUSTMENT (h 0/+50)  
/ TOP VERSION (h 0/+5)