



MAGISTRA PLUS 700 - SOLID TOP

**MTPE77FE**



ELECTRIC, ON ELECTRIC OVEN

**TECHNICAL DATA:**

External dimensions - WxDxH (cm)	70x71,4x85
Total power (kW)	14,3

**ADDITIONAL TECHNICAL DATA:**

Oven dimensions - WxDxH (cm)	56x66x31
Nr. Electric plate 2,25 kW	4
Electric oven (kW)	5,3
Supply (N)	400V 3N 50/60Hz
Weight (kg)	117
Volume (m3)	0,8

The cooking plate with a surface area of 40 dm<sup>2</sup> is in cast iron (10 mm thickness). For gas versions, the 9 kW stainless steel burner is placed under the removable central ring. Piezo-electric ignition and thermostatic control. For electric versions, the cooking plate is unique but has 4 cooking zone with independent control. 1 mm worktop in AISI 18/10 stainless steel. Excellent alignment with joints.

Versions with oven:

Stainless steel cooking chamber with enameled bottom, stainless steel double-wall door with insulating casing.

Gas oven: 6 kW burner (8 kW for maxi oven) with self-stabilizing flame; thermostatic temperature control with safety valve and thermocouple; piezo-electric burner ignition. 3 GN 2/1 rack support.

Electric oven: 5.3 kW stainless steel armoured heating elements placed on the bottom and on the top of the cooking chamber; thermostatic temperature control with separate bottom/top temperature control for maximum cooking flexibility. 3 GN 2/1 rack support.

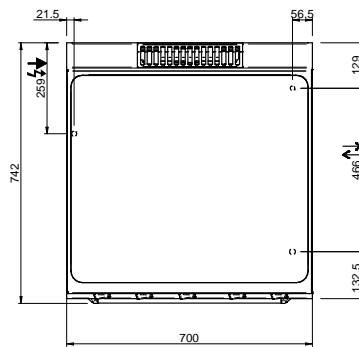
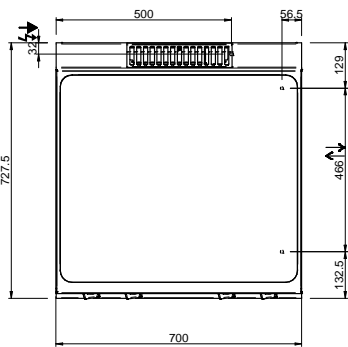
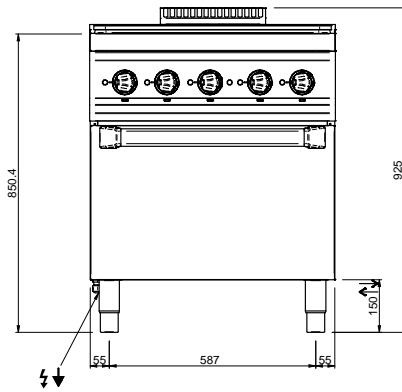
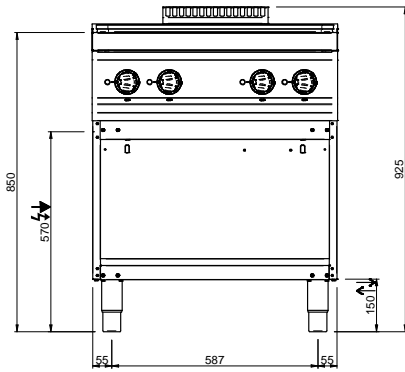

LEGENDA SIMBOLI / LEGEND



INGRESSO GAS / GAS INLET  
(EN 10226-1) Ø M 1/2"



INGRESSO ACQUA /  
WATER INLET Ø M 1/2"



ATTACCO EQUIPOTENZIALE /  
EQUIPOTENTIAL



ALIMENTAZIONE ELETTRICA /  
POWER SUPPLY



SCARICO ACQUA / OLII  
WATER / OILS DRAIN



REGOLAZIONE PIEDINI /  
FEET ADJUSTMENT (h 0/+50)  
/ TOP VERSION (h 0/+5)