



## DOMINA PRO 700 - NEUTRAL ELEMENTS

### N72T

---



#### TOP

##### TECHNICAL DATA:

---

External dimensions - WxDxH (cm) 20x73x25

Drawer

##### ADDITIONAL TECHNICAL DATA:

---

Weight (kg) 10

Volume (m3) 0,1

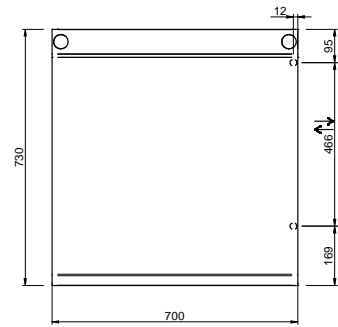
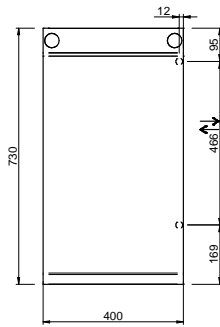
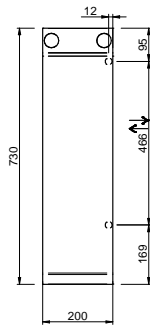
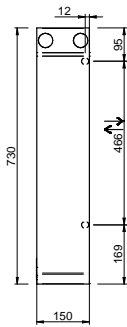
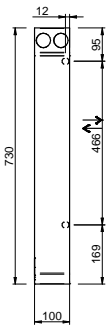
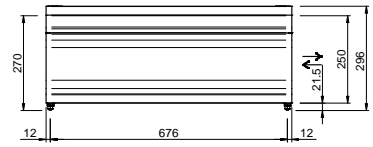
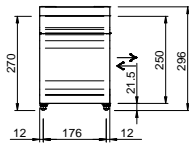
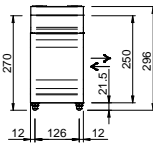
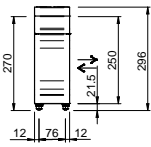

LEGENDA SIMBOLI / LEGEND



INGRESSO GAS / GAS INLET  
(EN 10226-1) Ø M 1/2"



ALIMENTAZIONE ELETTRICA /  
POWER SUPPLY



INGRESSO ACQUA /  
WATER INLET Ø M 1/2"



SCARICO ACQUA / OLII  
WATER / OILS DRAIN



ATTACCO EQUIPOTENZIALE /  
EQUIPOTENTIAL



REGOLAZIONE PIEDINI /  
FEET ADJUSTMENT (h 0/+50)  
/ TOP VERSION (h 0/+5)