



DOMINA PRO 700 - SOLID TOP

TPG77FG



GAS, ON GAS OVEN

TECHNICAL DATA:

External dimensions - WxDxH (cm)	70x73x85
Total power (kW)	16
IPX5	●

ADDITIONAL TECHNICAL DATA:

Oven dimensions - WxDxH (cm)	56x66x31
Gas oven (kW)	6
Weight (kg)	116
Volume (m3)	0,8

The cooking plate with a surface area of 40 dm² is in cast iron (10 mm thickness). For gas versions, the 9 kW stainless steel burner is placed under the removable central ring. Piezo-electric ignition and thermostatic control. For electric versions, the cooking plate is unique but has 4 cooking zone with independent control.

Versions with oven:

Stainless steel cooking chamber with enameled bottom, stainless steel double-wall door with insulating casing.

Gas oven: 6 kW burner (8 kW for maxi oven) with self-stabilizing flame; thermostatic temperature control with safety valve and thermocouple; piezo-electric burner ignition. 3 GN 2/1 rack support.

Electric oven: 5.3 kW stainless steel armoured heating elements placed on the bottom and on the top of the cooking chamber; thermostatic temperature control with separate bottom/top temperature control for maximum cooking flexibility. 3 GN 2/1 rack support.

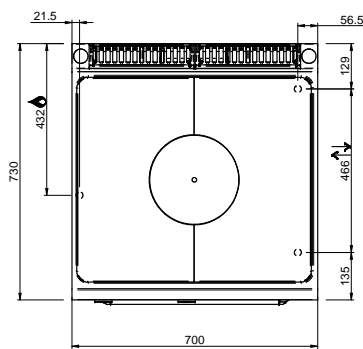
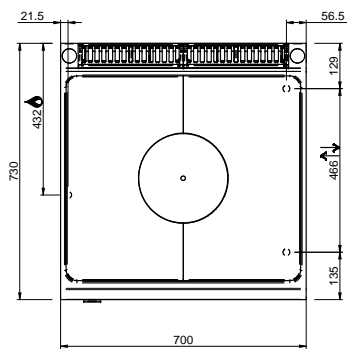
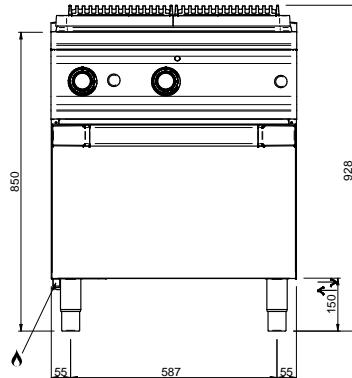
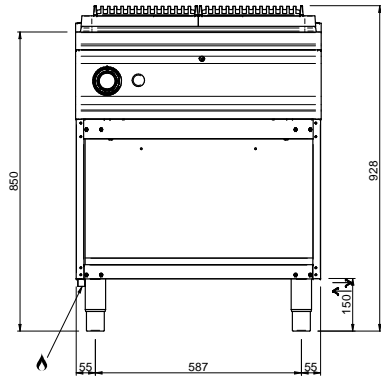

LEGENDA SIMBOLI / LEGEND



INGRESSO GAS / GAS INLET
(EN 10226-1) Ø M 1/2"



ALIMENTAZIONE ELETTRICA /
POWER SUPPLY



INGRESSO ACQUA /
WATER INLET Ø M 1/2"



SCARICO ACQUA / OLII
WATER / OILS DRAIN



ATTACCO EQUIPOTENZIALE /
EQUIPOTENTIAL



REGOLAZIONE PIEDINI /
FEET ADJUSTMENT (h 0/+50)
/ TOP VERSION (h 0/+5)