

Glasswasher

G504-10B

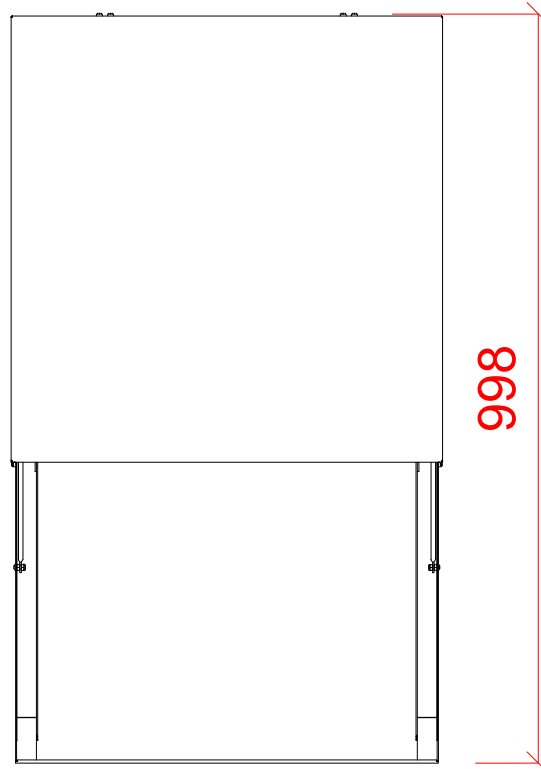
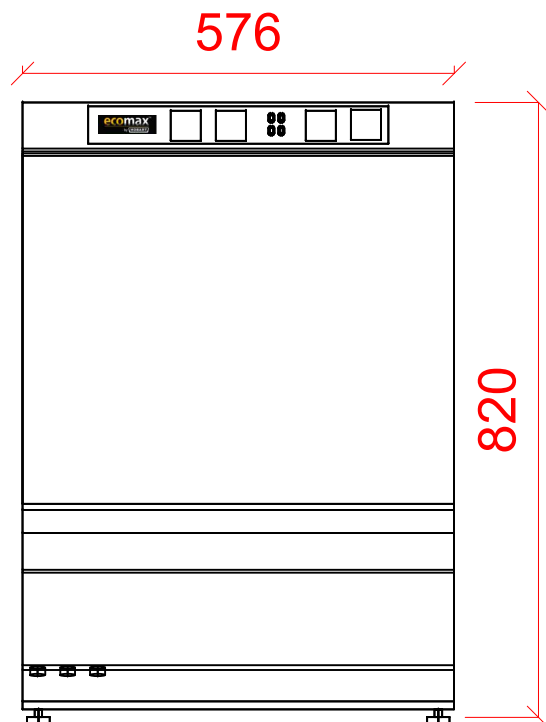
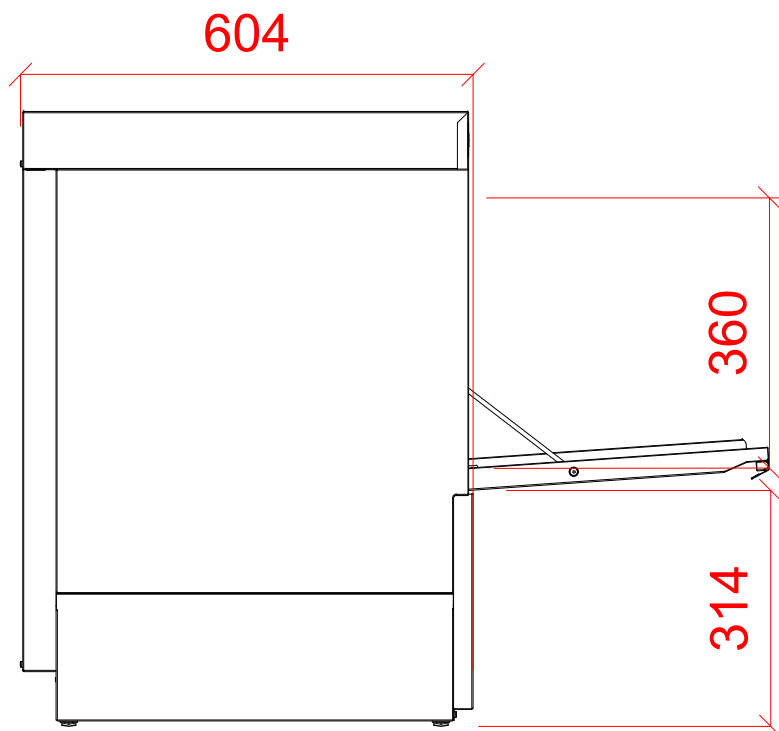

**1** Water

22mm CONNECTION VIA 2 METRE FLEXIBLE HOSE, FEMALE TERMINATION.

WATER SUPPLY 15°C TO 65°C  
@ 0.8 TO 6.0 BAR MAX.  
INITIAL TANK FILL 25 LITRES.  
RINSE WATER USAGE 2.3 LITRES PER CYCLE. MAX USAGE 138 LITRES PER HOUR.

**2** Drain

DRAIN: 2.0 METRE FLEXIBLE HOSE TO A 40mm TRAPPED STANDPIPE  
650mm MAX A.F.F.L.

FLOW RATE 30 LITRES PER MINUTE.

**Other Services**

RINSE AGENT HOSE - 2.5 METRE FLEXIBLE.  
DETERGENT HOSE - 2.5 METRE FLEXIBLE.

**3** Electric

4.1kW 230/50/1 FUSED AT: 1 x 25amps.  
CONFIGURABLE TO:  
5.9kw 400/50/3 FUSED AT: 3 x 16amps  
2.2kW 230/50/1 FUSED AT: 1 x 13 amps  
MACHINE SUPPLIED WITH 2.0 METRES OF CABLE

**Notes**

+40mm ADJUSTMENT FOR FEET  
NET WEIGHT 46kg.