



GENERAL FEATURES

- Rack size **50x50 cm**
- Gross weight: 67 Kg
- Washing cycles/racks/hour:
90"-120"-180"-9'/40-30-20-7
- Bottom wash/rinse arm
- Wash pump: 550 W
- Boiler capacity: 5 liters
- Tank capacity: 20 liters
- Boiler heating element: 2,7 kW
- Tank heating element: 2,4 kW
- Water consumption per cycle: 2 liters
- Electronic controls with LCD display
- Useful washing height: 340 mm
- Magnetic door microswitch
- Automatic water filling
- Double electric detergent and rinse dispenser
- Hot rinse
- Thermostop function
- Anti back-flow valve
- Green function for energy saving
- Automatic end-of-day self cleaning of water tank
- Washing pump with Soft-Start

FILTRATION

- Plastic wash pump filter, easily removable

BODY

- AISI 304 stainless steel Body
- Double skinned body
- Preformed wash tank
- Preformed rack guides
- Door handle in s/s
- Wash/rinse arms in s/s, easily removable
- Boiler in s/s AISI 304
- PVC protection rear the bottom front panel

EQUIPMENT AS GLASSWASHER

- 1 glass racks 50x50 cm
- 1 cutlery small basket
- 1 insert for saucers
- 1 inlet hose (length 2 mt)
- 1 drain hose (length 2,5 mt)

OPTIONAL

- Drain pump
- Cold rinse
- 380-415V3N~50Hz Version
- Hot water filling
- 60 Hz version
- Kit booster pump
- Kit 4 high feet
- Kit surface filters

ACCESSORIES FOR THE WATER TREATMENT

- Internal water softener ("S" version)

ACCESSORIES

- Special racks
- S/S supporting stand h. mm. 550 for baskets

INSTALLATION

- Use the screws of the feet and a spirit level to ensure that the machine is levelled

MAIN POWER SUPPLY

- The voltage of main power supply must be compatible with the rated voltage
- The machine must be connected to a suitable earth (ground) system
- Connect the machine power socket to the multi-pole wall outlet provided

WATER SUPPLY CONNECTION

- A water softener must be installed if the water is hard
- The water pressure must be between 0.2MPa (2 bar), and, 0.5MPa (5 bar)
- The temperature of the water-supply must be between 10°C to 50°C

TECHNICAL SPECIFICATIONS

- Voltage: **220-240 V ~ 50 Hz**
- Total power: **3,25 kW**
- Amperage: **14 A**
- Power cord supply size: **3 x 1,5 mmq**

AS 50.35^E M

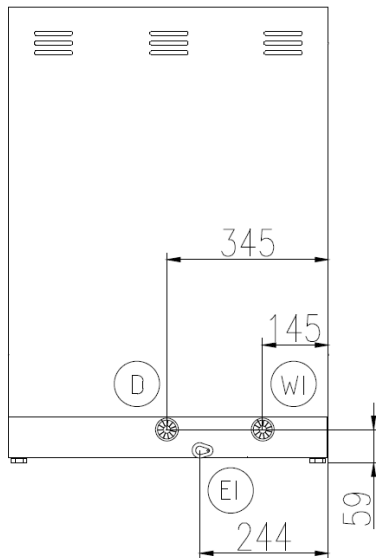
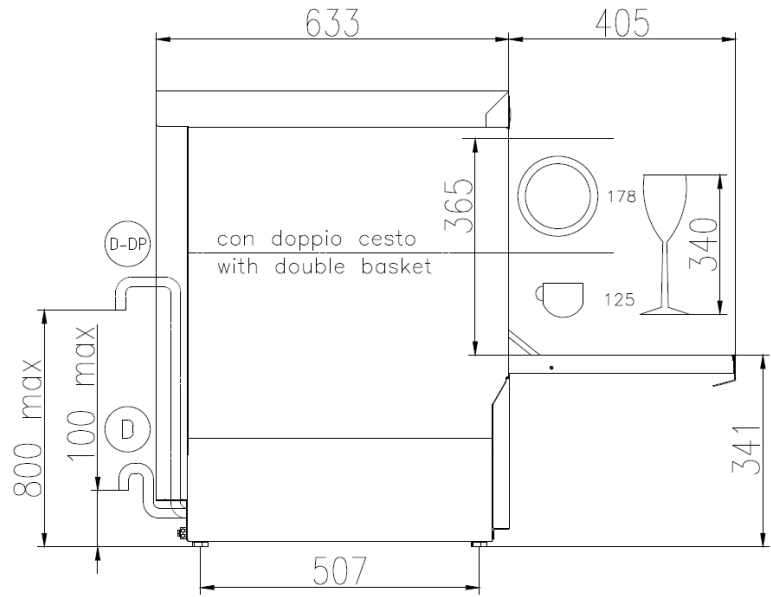
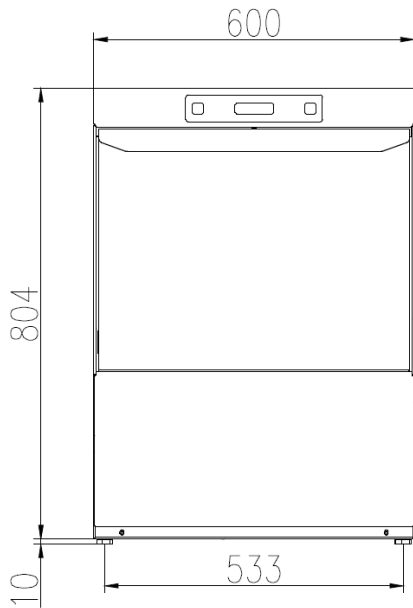

- EI CAVO DI ALIMENTAZIONE
POWER CORD SUPPLY
CABLE D'ALIMENTATION
CABLE DE ALIMENTACION

- WI CANNA DI CARICO G 3/4 L=2000 mm
G 3/4 INLET HOSE L=2000 mm
TUYAU D'ALIMENTATION G 3/4" L=2000 mm
TUBO DE ALIMENTACION G 3/4" L=2000 mm

- D TUBO DI SCARICO ø 29 mm L=2500 mm
DRAIN HOSE ø 29 mm L=2500 mm
TUYAU DE VIDANGE ø 29 mm L=2500 mm
TUBO DE DESAGUE ø 29 mm L=2500 mm

- D-DP TUBO DI SCARICO ø 29 mm L=2500 mm (CON POMPA SCARICO)
DRAIN HOSE ø 29 mm L=2500 mm (WITH DRAIN PUMP)
TUYAU DE VIDANGE ø 29 mm L=2500 mm (AVEC POMPE DE VIDANGE)
TUBO DE DESAGUE ø 29 mm L=2500 mm (CON POMPA DE DESAGUE)

	Min 10°C-MAX 50°C
	Min 10°C-MAX 25°C with ENERGY RECOVERY
	200÷500kPa(2÷5 Bar)
	100÷500kPa(1÷5 Bar) with ATMOSPHERIC BOILER
	HARDNESS 5÷20°f-2,8÷11°d